

ATRIO-SHADE, MOTORIZED ROLLER SHADES FOR INTERIOR USE:

PRODUCT SPECIFICATIONS

The Atrio-shade system shall consist of an aluminum roller tube, a fabric or filament shade, a tubular motor, bracketry and motor controls

SHADE: A woven fabric or filament type shade of but not limited to the following types: woven fiberglass/PVC mesh, woven polyester mesh, laminated PVC/fiberglass, Mylar film, acrylic coated cotton, PVC treated cotton, acrylic canvas, polyester cambric, cotton duck, woven cellulosic fiber, cotton and flax.

BOTTOM RAIL: 1) To consist of sewn hem pocket enclosing a 1/4" x 1" oval aluminum slat. 2) An external bottom rail of rolled steel or extruded aluminum secured to the shade by a stapled batten.

ROLLER: Aluminum in alloy 6061 or 6063, temper: T-6. Diameters ranging from 1" to 2.75" depending on shade size.

HEAD VALANCE: To be extended aluminum with profile dimensions of 3" x 3" or 4" x 4". Opening at bottom for shade egress is maximum 2 1/4" wide. End caps to be: 1) Formed steel with integral motor bracket or 2) Aluminum plate (.065 minimum thickness).

MOTOR: 1) Motor shall be asynchronous capacitor start and run, single phase type 120V-60HZ, thermally protected, totally enclosed, brushless motor, equipped with permanently lubricated bearings requiring no maintenance. Motors may be 12V, 24V, 120V or 220V. 2) brake shall be a solenoid activated disc brake which shall automatically stop and hold load in position without any slippage, whenever current to the motor is interrupted. 3) gearbox shall have planetary type gears, lubricated for lifetime service. 4) limit switches shall incorporate two external thumb screws to allow for exact setting of length of travel. Limit switch setting shall not be affected by roller tube travel.

CONTROLS: To be double throw, center off rocket switch unless other controls (automated, remote) are specified.

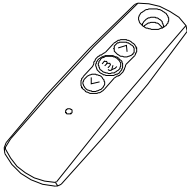
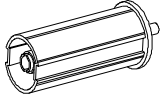
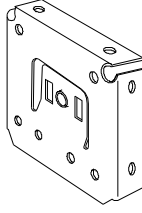
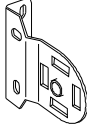
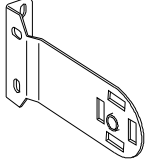
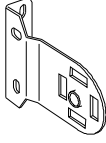
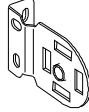
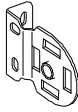
 <p>(a)</p>	 <p>(b)</p>	 <p>(c)</p>	 <p>(d) SL660 1.5"proj.</p>
 <p>SL690 2.875" proj</p>	 <p>SL680 2" proj.</p>	 <p>NB660 1.5" proj.</p>	 <p>NB650 1.25" proj.</p>

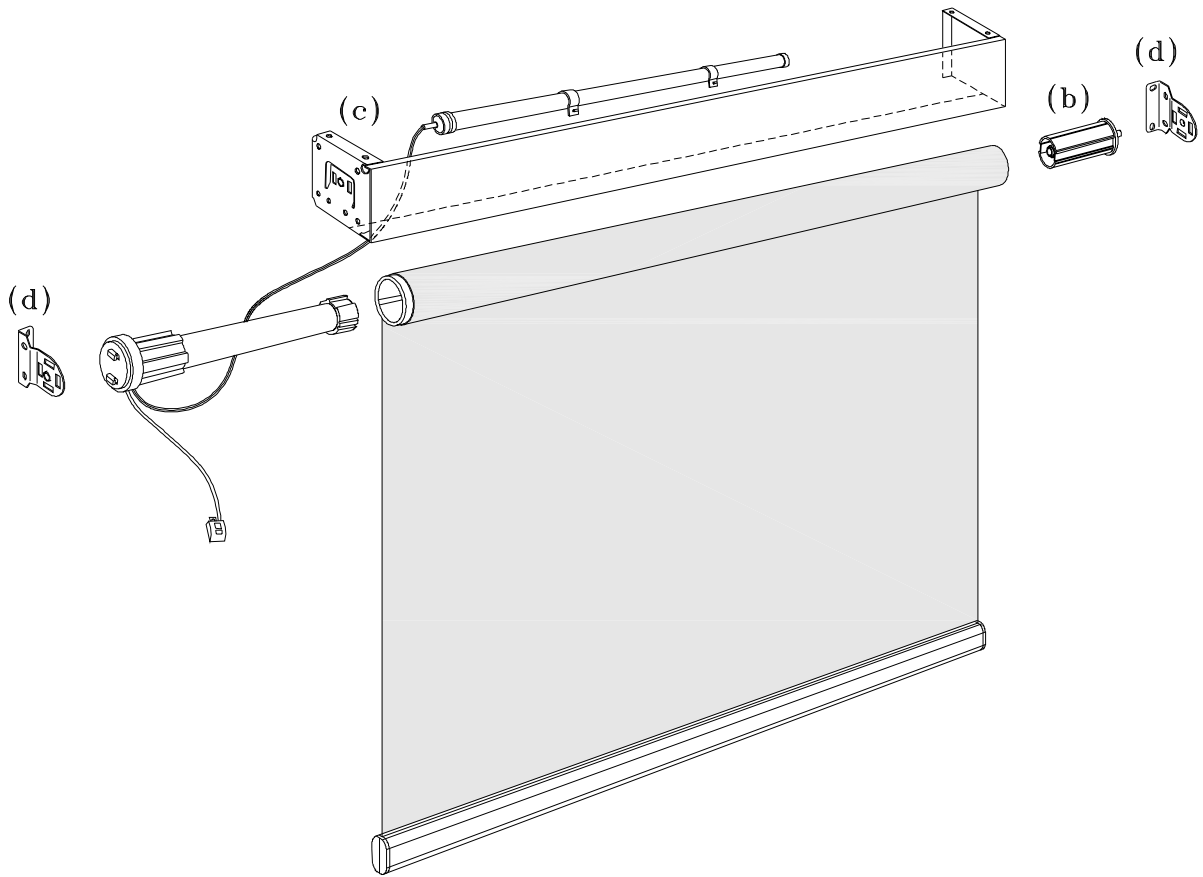

BATTERY DRIVE ROLLER SHADE

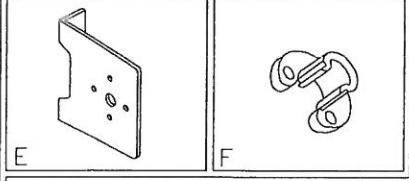
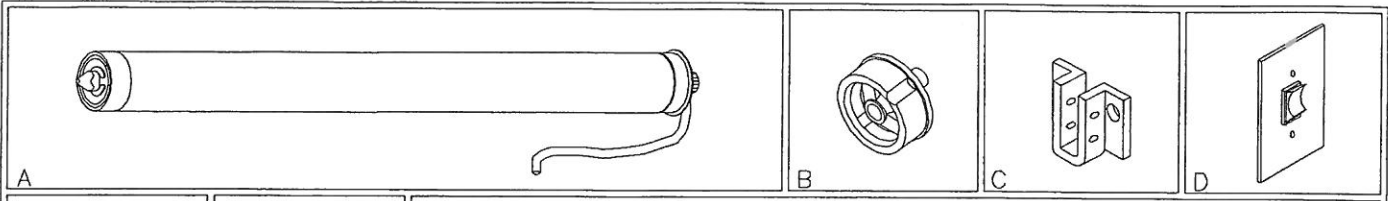

Motorized Roller Shade

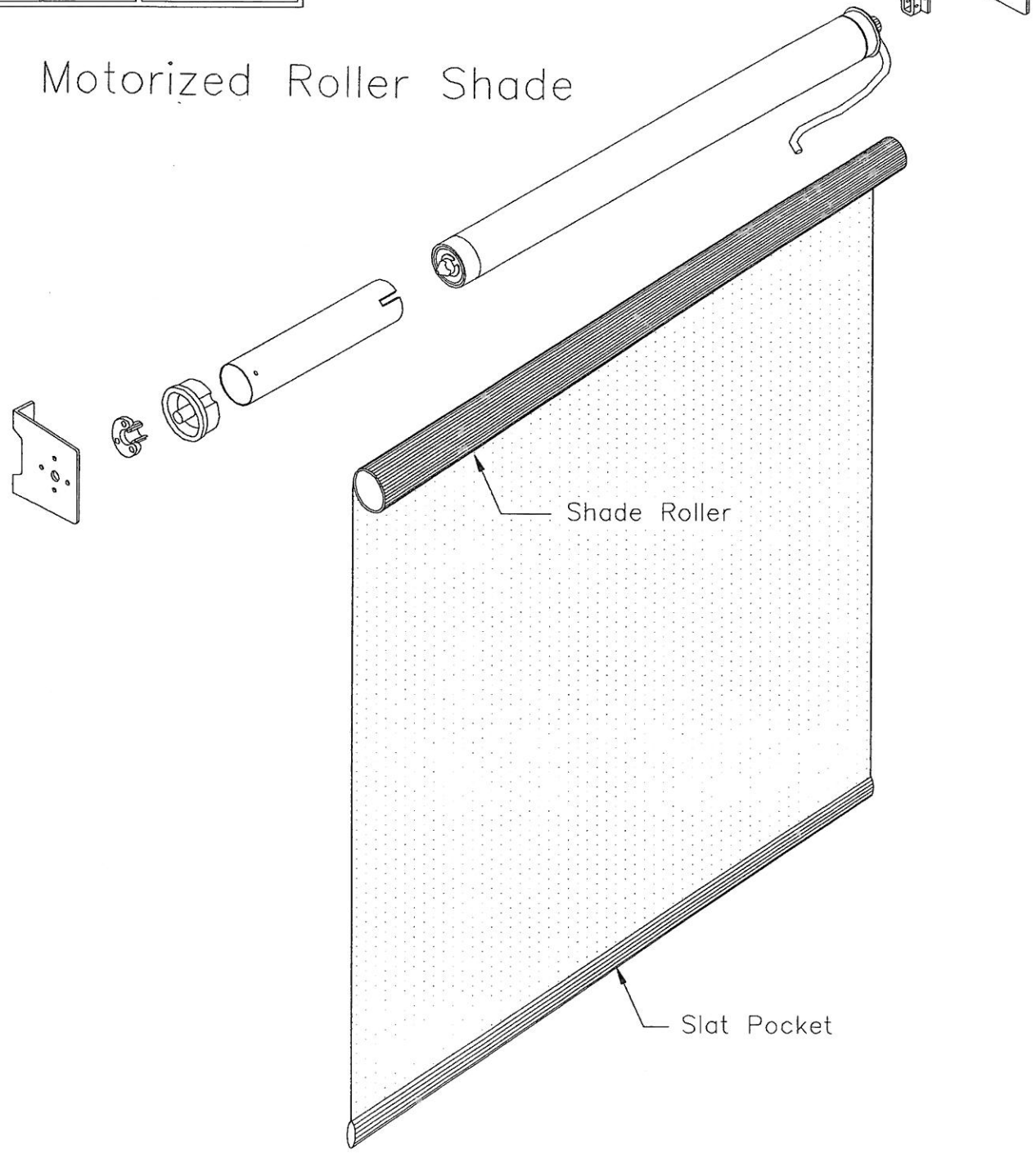

Shade Roller

Slat Pocket

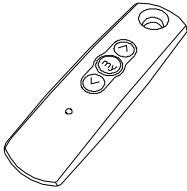
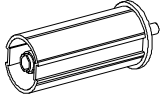
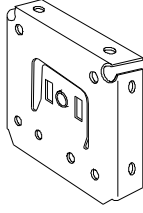
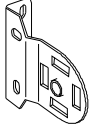
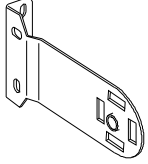
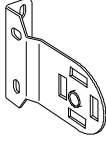
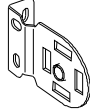
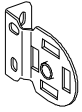
 <p>(a)</p>	 <p>(b)</p>	 <p>(c)</p>	 <p>(d) SL660 1.5"proj.</p>
 <p>SL690 2.875" proj</p>	 <p>SL680 2" proj.</p>	 <p>NB660 1.5" proj.</p>	 <p>NB650 1.25" proj.</p>

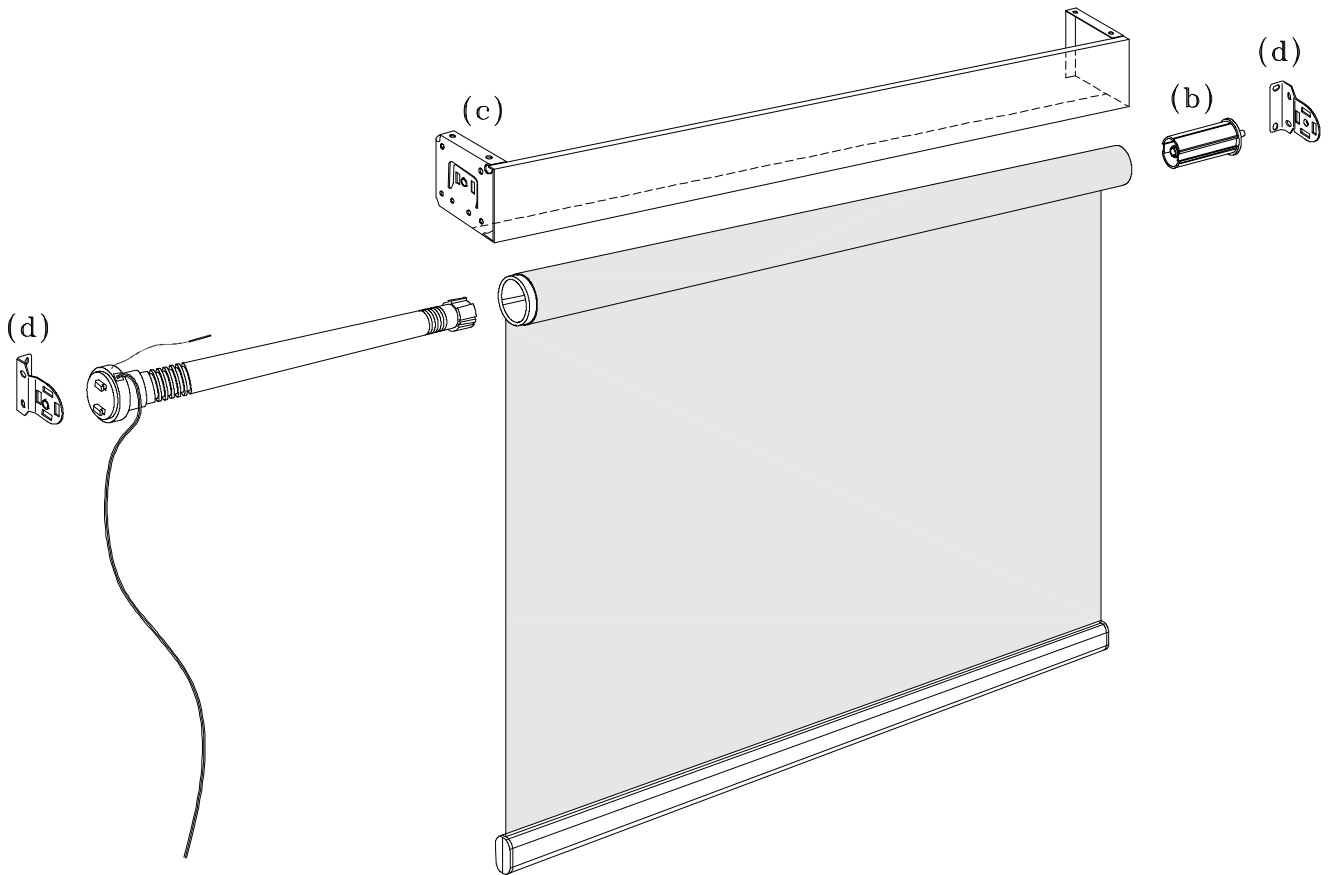

SONESSE-30 MOTOR ROLLER SHADE